

DAVIS & WADDELL

essentials

Electric Ice Cream Maker

DES0318

www.davisandwaddell.com.au

Thank you for choosing the Davis & Waddell Electric Ice Cream Maker. To ensure proper operation and to maintain the lifespan of your appliance, please read these instructions carefully before use.

Features

- 1.5 litre capacity
- Transparent, easy-to-remove cover
- Easy-to-remove paddle
- Simple, one-switch operation
- Non-slip feet
- 220-240V ~ 50Hz

1. Power unit
2. Lid
3. Paddle
4. freezer bowl
5. On/off button
6. Chute

Safety First

This appliance is not intended for use by persons (including children) with reduced physical, sensory or mental capabilities, or lack of experience and knowledge, unless they have been given supervision or instruction concerning use of the appliance by a person responsible for their safety.

- Read all the instructions before operating appliance and retain for future use.
- This appliance is intended for indoor household use only.
- The supply cord should be regularly examined for signs of damage, and if the cord is damaged, the appliance must not be used.
- If the supply cord is damaged, it must be replaced by qualified persons in order to avoid a hazard.
- Pull out from power outlet by grasping the plug – do not pull the cord.
- Do not use an extension cord.
- Do not immerse appliance, plug or cord in water or any other liquid.
- Do not allow cord to touch hot surfaces.
- This appliance is not to be operated by means of an external timer or separate remote-control system.
- Unplug appliance when not in use or when being cleaned.
- The appliance should always be used on a hard and stable surface, such as a table or benchtop.
- Do not use appliance for anything other than its intended use.
- Do not use a damaged appliance.
- Avoid spillage on the connector.
- Switch off the appliance and disconnect from supply before changing accessories or approaching moving parts, or cleaning.
- This appliance is intended to be used in household and similar applications such as:
 - staff kitchen areas in shops, offices and other working environments;
 - farm houses;
 - by clients in hotels, motels and other residential type environments;
 - bed and breakfast type environments.
- Children should not use this machine unsupervised. Do not let the cord hang

- down where a child could grab it.
- Do not operate any appliance with a damaged cord or plug, or after the appliance malfunctions, is dropped, or has been damaged in any manner.
- To protect against the risk of fire, electric shock, or personal injury, do not place the cord, plug, or unit in water or other liquids.
- Never use an unauthorized attachment.
- Avoid contact with moving parts. Keep hands, hair, clothing, spatulas and other utensils away during operation to reduce the risk of injury to persons and/or damage to the machine.
- Never leave the machine on unattended.
- Do not let children play with this machine.
- Only use the machine for its intended domestic use.
- Always make sure appliance is thoroughly clean before making ice cream or sorbet.
- Never freeze ice cream that has been fully or partially defrosted.
- Any ice cream or sorbet containing raw ingredients should be consumed within one week. Ice cream tastes best when fresh.
- Ice cream or sorbet that contains raw or partially cooked eggs should not be given to young children, pregnant women, the elderly or people with compromised immune systems.
- To prevent freezer burn, always ensure that hands are protected when handling the bowl, especially when first removed from the freezer.
- If the freezing solution appears to be leaking from the bowl, discontinue use. The freezing solution is non toxic.

- Do not place the machine on hot surfaces such as stoves, hotplates or near open gas flames.

Packaging and Recycling

The materials used for this product's packaging can be reused, recycled and disposed of through specific waste streams.

- REUSE: Keep packaging to safely store or transport your appliance, preventing damage.
- RECYCLE: Look for recycling symbols on packaging components to identify if they are recyclable. Check with your local authority to find out what materials are accepted for recycling in your area.
- DISPOSE: Look for symbols on packaging components and dispose of materials accordingly.

Operating Your Ice Cream Maker Before First use

1. Remove all packaging.
2. Wash parts: see "Cleaning".

Preparing Ice Cream Maker

1. 8-12 hours before using, place freezer bowl into freezer.
2. Prepare ice cream or sorbet mix (see recipe ideas). Allow mix to cool in refrigerator.
3. Fit power unit into lid. It will click into place.

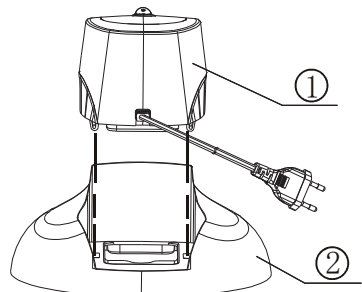

4. Fit paddle into power unit.

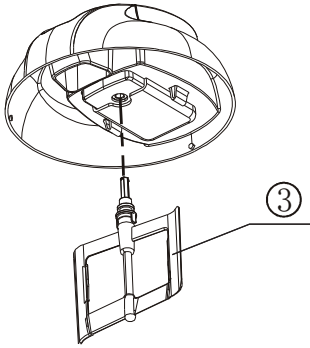

5 Remove freezer bowl from freezer.

6. Lower assembled lid/powerunit/ paddle onto the freezer bowl and turn clockwise to lock into position.

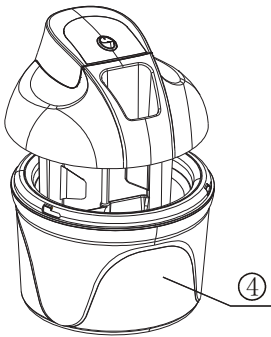

You can now switch ice cream maker on using on/off button.

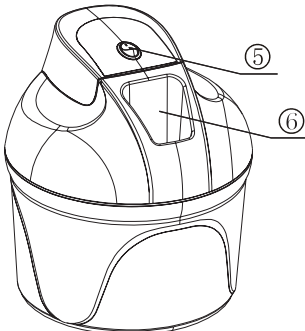

THE MACHINE MUST BE SWITCHED ON BEFORE ADDING THE ICE CREAM OR SORBET RECIPE TO PREVENT THE MIX FROM IMMEDIATELY FREEZING ON THE INSIDE OF THE BOWL.

6. Use chute to pour ice cream or sorbet mix into freezer bowl.

When pouring mixture into bowl, always stop at least 4cm from the top, as mixture will increase in volume during freezing.

7. Allow mixture to churn until frozen or desired consistency is reached. This can take 15 to 30 minutes, but most recipes will be ready in less time.

8. Switch off, remove the power unit/lid. The ice cream is ready to serve.

The ice cream produced should be a soft spoonable type. This can be transferred to a separate container for storage in the freezer or if you wish to firm the ice cream before eating.

Important

- Do not stop and start machine during freezing process, as mixture may freeze in contact with the bowl and prevent movement of paddle.
- To avoid overheating motor, direction of rotation will change if mixture becomes too thick. If direction of rotation continues to change, stop machine when mixture is ready.
- If need be, direction of rotation can be manually changed. Switch appliance off, wait a few moments and switch back on. Paddle should rotate opposite direction.
- In the unlikely event of the motor overheating, a safety cut out will operate causing motor to stop. If this happens, switch off, unplug machine and allow power unit to cool.
- Do not use metal utensils to remove mix from bowl.

- Do not remove freezer bowl from freezer until ready to make ice cream.

Tips

- Place freezer bowl in a plastic bag before freezing. Freeze bowl in an upright position.
- Always make sure freezer bowl is thoroughly dry before placing in freezer.
- Do not puncture or heat freezer bowl.
- Freezer bowl should be placed in a freezer that is operating at a temperature of -18°C or colder for 8 hours before use.
- For best results always refrigerate ingredients before making ice cream.
- The addition of alcohol to recipes inhibits freezing process.

Cleaning

- Always switch off, unplug and dismantle before cleaning.
- Never put power unit in water or let cord or plug get wet.
- Do not wash parts in dishwasher.
- Do not clean with scouring powders, steel wool pads, or other abrasive materials.

Freezer Bowl

- Allow freezer bowl to reach room temperature before cleaning.
- Wash inside of bowl, then dry thoroughly. Do not immerse in water.

Paddle

- Remove paddle from power unit.
- Wash then dry thoroughly.

Lid

- Wash then dry thoroughly.

Power unit

- Wipe with a damp cloth, then dry.

Specifications

Device type	Ice Cream Maker
Model	DES0318
Voltage supply	220-240V ~ 50Hz
Power consumption	12W
Capacity during operation	1.5L
Production class	II

Our 12 month Guarantee

In Australia, our goods come with guarantees that cannot be excluded under the Australian Consumer Law. You are entitled to a replacement or refund for a major failure and compensation for any other reasonably foreseeable loss or damage. You are also entitled to have the goods repaired if the goods fail to be of acceptable quality and the failure does not amount to a major failure.

We stand by this product. Therefore we offer a 12 month guarantee on the motor. The benefits of this guarantee are in addition to any rights and remedies imposed by Australian Consumer Law. Our guarantee excludes normal wear and tear and instances where care and use instructions have not been followed.

What Albi will do: During this guarantee period Albi will repair, replace or refund any defective product. If identical product is not available for replacement, a similar product may be offered. Albi asks you to cover the cost of postage/transit if the product needs to be sent back to us for inspection. If Albi deems the product is defective, we will reimburse your postage/transit expenses. Albi will be responsible for the postage/transit of the repaired/replacement product back to you.

What to do: If a fault/defect is identified cease using the product immediately.

To make a claim on this guarantee,

take the product, proof of purchase and full details of the alleged defect to the retailer from whom the product was purchased. If you cannot access the retailer or are unsatisfied with the solution offered by the retailer contact Albi via the details below.

Albi

87 Chifley Drive, Preston, Victoria 3072

P: +61 (03) 9474 1300

E: albi@albi.com.au

www.albi.com.au

Recipes

Simple Vanilla Ice Cream

Ingredients

- 1 cup milk
- ½ cup sugar
- 2 cups thickened cream
- 1-2 tsp. vanilla extract (to taste)

Method

1. In a medium bowl combine milk and sugar, with a hand or electric mixer until sugar has dissolved (about 1-2 mins).
2. Stir in cream and vanilla extract. Cover and refrigerate until well chilled.
3. Remove freezer bowl from freezer and assemble unit as per instructions. Switch appliance on and pour mix through chute into freezer bowl.
4. Churn mixture until it thickens (about 25-30 mins).
5. Ice cream produced should be soft and easy to spoon out. For a firmer ice cream, remove from freezer bowl, place in separate freezer-safe container, cover and freeze for a further 1-2 hours.

Flavour variations

- Coffee – omit vanilla and add 2 tsp. instant coffee or 2 tbsp. cold espresso coffee when combining milk and sugar.
- Mint Choc Chip – omit vanilla and replace with 1 to 1½ pure peppermint extract. During last 5 minutes of mixing.
- Fruit – add 2/3 cup of fruit puree during last 5 minutes of mixing.

Fruit Sorbet

Ingredients

- 2 cup caster sugar
- 1 cup water
- 500mL fruit puree, well chilled

Method

1. Combine sugar and water in a small saucepan over medium heat. Stir about 3 mins or until sugar has dissolved. Simmer 1 min, remove from heat and cool for 10 mins. Refrigerate for 3 hours until mixture is chilled.
2. Pour fruit puree and sugar syrup into a large jug and stir until combined.
3. Remove freezer bowl from freezer and assemble unit as per instructions. Switch appliance on and slowly pour mix through chute into freezer bowl.
4. Churn mixture until it thickens (about 25-30 mins).
5. Sorbet produced should be soft and easy to spoon out. For a firmer sorbet, remove from freezer bowl, place in separate freezer-safe container, cover and freeze for a further 1-2 hours.

Flavour suggestions

- Raspberry – blend or process 750g fresh or frozen (thawed) raspberries until smooth. Strain mixture through a fine sieve to remove seeds for a smooth puree.

- Passionfruit – blend or process pulp of 2kg passionfruit (about 30 fruit) for 20 seconds or until seeds separate from juice. Over a large bowl, strain mixture through a fine sieve, pressing down with a wooden spoon to remove seeds for a smooth puree. Reserve 2 tbsp. seeds and combine with puree to give mixture more texture.
- Mango – blend or process 500g fresh, skinned, de-seeded and chopped (or frozen) mango until smooth.

8. Ice cream produced should be soft and easy to spoon out. For a firmer ice cream, remove from freezer bowl, place in separate freezer-safe container, cover and freeze for a further 1-2 hours.

Flavour variations

- Cookies and cream – during the last 5 mins of mixing add $\frac{3}{4}$ cup crushed chocolate cream biscuits.
- Green tea or matcha – add 20g green tea/matcha powder when adding egg and sugar mixture to milk.

Traditional Vanilla Ice Cream

Ingredients

- 4 free range egg yolks
- $\frac{1}{2}$ cup granulated sugar
- 1 cup full cream milk
- 1 cup thickened cream
- 2 tsp. vanilla extract or vanilla bean paste

Method

1. Add egg yolks and sugar to bowl and whisk until they are a pale yellow colour, (approx. 5 mins).
2. In a saucepan, heat milk over low heat until heated through (do not boil). Gradually add egg and sugar mixture to warmed milk and stir well.
3. Return to low heat, stirring constantly until mixture coats the back of a spoon (again do not boil).
4. Remove from heat and allow to cool slightly. Cover and refrigerate until cold (approx. 2-3 hours). Note the longer the custard mixture chills, the creamier ice cream will be.
5. Once custard mixture is sufficiently chilled, stir in thickened cream and vanilla until combined.
6. Remove freezer bowl from freezer and assemble unit as per instructions. Switch appliance on and slowly pour mixture through chute into freezer bowl.
7. Churn mixture until it thickens (about 25-30 mins).

Vegan Coconut & Chocolate Ice Cream

Ingredients

- 2 x 400mL tins coconut cream or full fat coconut milk
- $\frac{1}{2}$ cup granulated sugar
- 1 tsp. vanilla extract or vanilla bean paste
- 1 tbsp. cocoa

Method

1. Combine coconut cream/milk, sugar, vanilla and cocoa into a blender and blend on high until sugar has dissolved (about 1-2 mins).
2. Remove freezer bowl from freezer and assemble unit as per instructions. Switch appliance on and slowly pour mix through the chute into the freezer bowl.
3. Churn mixture until it thickens (about 30-45 mins).
4. Ice cream produced should be soft and easy to spoon out. For a firmer ice cream, remove from freezer bowl, place in separate freezer safe container, cover and freeze for a further 1-2 hours. Will keep in the freezer for up to 10 days, though best when fresh.

Texture variation

Add $\frac{1}{2}$ cup shredded coconut and $\frac{2}{3}$ cup vegan choc chips during the last 5 minutes of mixing.